

GALVANISED STEEL AIR REGULATION DAMPERS PITCH 100MM

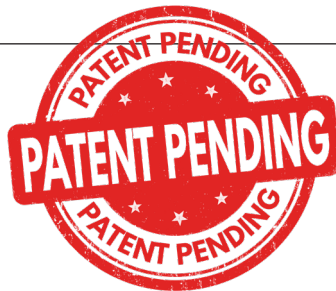

ETZ100 Series

Patented galvanised steel regulation dampers, pitch 100mm with nylon rotation pins. They can be placed in the regulation and in the balance of air flow and pressure, in the air conditioning and ventilation systems and treatments centres. This innovative damper, thanks to a special shaping of the frame and stopper of the fins, it guarantees considerable advantages: 1) Completely free air passage 2) Strong reduction of pressure drop 3) Strong reduction of self-generated noise. These shrewdness, combined with the

particular plastic elements inserted at the ends of the fins, also guarantee a limited leakage of the air with closed damper. An innovative universal metal plate allows the application of all manual or motorized controls. The opening and closing of the fins takes place by a manual control placed on one side of the damper connected to an external lever system. The same movement can be achieved through a wide range of servomotors that allow a more precise adjustment of the passage of air in the duct.

CONSTRUCTIVE FEATURES:

Material: galvanised steel casing and fins control pin $\varnothing 12$ mm in galvanised steel pins for movement in nylon PA6

Installation: with bolts on slotted holes (detail 2) placed in the angle of the frame and on additional intermediate holes (detail 3)

Operating temperature: -20 °C/ +70°C

CONSTRUCTION DETAILS:

- 1) Flanged casing
- 2) Slotted holes for fixing
- 3) Additional holes for fixing
- 4) Calibration fin
- 5) Lever system and pivot in nylon PA6
- 6) Control pivot
- 7) Universal plate for manual control or servomotor.

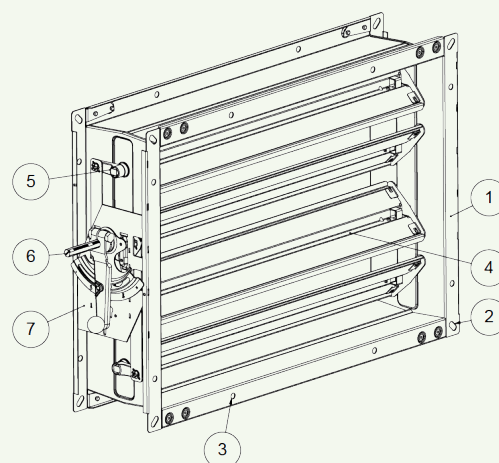

AVAILABLE MODELS:

- **ETZC100P** damper with opposed movement fins with pivot diam. 12mm
- **ETZC100C** damper with opposed movement fins with manual control (accessory)

SPECIAL EXECUTIONS ON REQUEST:

- **ETZP100P** damper with parallel movement fins with pivot diam. 12mm
- **ETZP100C** damper with parallel movement fins with manual control (accessory)

ACCESSORIES:

EARG175K

manual control

ETZS1

plate for servomotors Belimo serie SM, GM

**BELIMO
SERVOMOTOR**

electric servomotor

ETZS2

plate for servomotors Belimo serie NF, SF, EF

PIVOT AND UNIVERSAL PLAT (STANDARD)

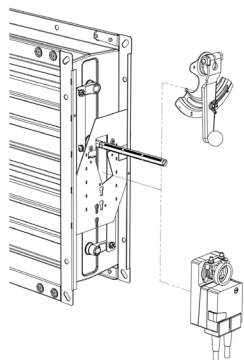

MANUAL CONTROL

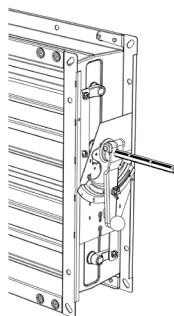

SERVOMOTOR

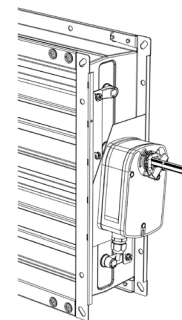

DIMENSIONAL FEATURES:

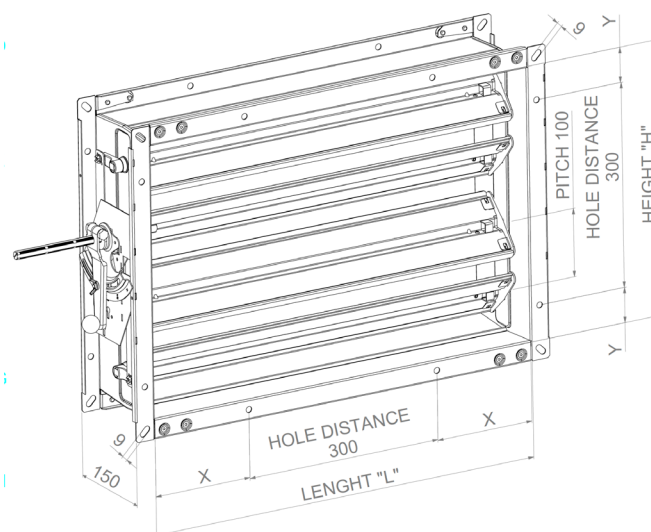
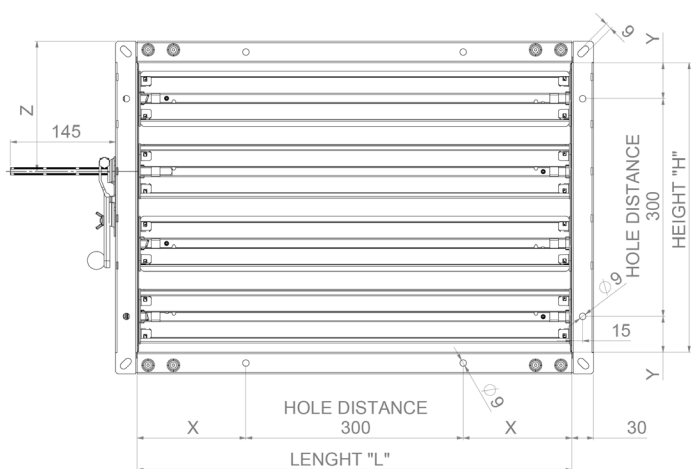

L (mm)	x (mm)	L (mm)	x (mm)	L (mm)	x (mm)
-	-	1100	100	2100	150
200	-	1200	150	2200	200
300	-	1300	200	2300	100
400	200	1400	100	2400	150
500	100	1500	150	2500	200
600	150	1600	200	2600	100
700	200	1700	100	2700	150
800	100	1800	150	2800	200
900	150	1900	200	2900	100
1000	200	2000	100	3000	150

H (mm)	y (mm)	Z (mm)	H (mm)	y (mm)	Z (mm)	H (mm)	y (mm)	Z (mm)
-	-	-	1100	100	550	2100	150	1050
200	-	50	1200	150	550	2200	200	1050
300	-	150	1300	200	650	2300	100	1150
400	200	150	1400	100	650	2400	150	1150
500	100	250	1500	150	750	2500	200	1250
600	150	250	1600	200	750	2600	100	1250
700	200	350	1700	100	850	2700	150	1350
800	100	350	1800	150	850	2800	200	1350
900	150	450	1900	200	950	2900	100	1450
1000	200	450	2000	100	950	3000	150	1450

STANDARD DIMENSIONS TABLE:

Length L (mm)									
-	200	300	400	500	600	700	800	900	1000
1100	1200	1300	1400	1500	1600	1700	1800	1900	2000
2100	2200	2300	2400	2500	2600	2700	2800	2900	3000

Height H (mm)									
-	200	300	400	500	600	700	800	900	1000
1100	1200	1300	1400	1500	1600	1700	1800	1900	2000
2100	2200	2300	2400	2500	2600	2700	2800	2900	3000

NOMINAL DIMENSIONS:

For damper with length (L) > 1250 mm ≤ 2500 mm will be placing a breaker with thickness 30mm in central position.

For damper with length (L) > 2500mm ≤ 3000 mm will be placing two breakers with thickness 30mm with same distance. Dampers can have these maximum dimensions:

$L \leq 3000 \times H \leq 1500$

$L \leq 2000 \times H \leq 2000$

$L \leq 1500 \times H \leq 3000$

NON-STANDARD DIMENSIONS:

Dampers of series **ETZ** can be produced with non-standard dimensions in the size limits of the table. The total closing of non-standard damper is guarantee by special profiles mounted directly on the fins and not on the case as commonly done until today; this guarantees the maintenance of the complete air passage section, with obvious benefits of self-generated noise and pressure drop.

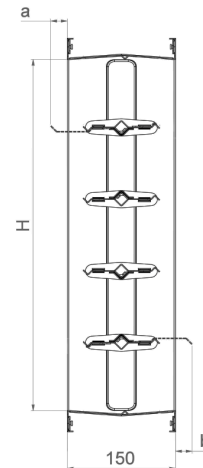

MAXIMUM FINS PROTRUSION OF STANDARD VERSION

Heights H (mm)	Heights increase (mm)	a	b
200, 300, 400, 500, 600, 700, 800, 900, 1000, 1100, 1200, 1300, 1400, 1500, 1600, 1700, 1800, 1900, 2000, 2100, 2200, 2300, 2400, 2500, 2600, 2700, 2800, 2900, 3000	10	0	0
	20	0	0
	30	8	0
	40	18	0
	50	3	3
	60	8	8
	70	18	8
	80	18	18
	90	23	23

FINS PROTRUSION OF SPECIAL VERSION:

Damper available with height > H+30 for which are adopted specific shrewdness to reset protrusions, except for height H+90 for which there will be a=3mm, b=3mm

MAXIMUM COUPLE SERVOMOTOR (Nm)

GROSS DAMPER SURFACE (m²):

			L (mm)													
			200	300	400	500	600	700	800	900	1000	1100	1200	1300	1400	1500
H (mm)	200	Nm	2	2	2	2	2	2	2	2	2	2	2	2	2	2
		S (m ²)	0,04	0,06	0,08	0,1	0,12	0,14	0,16	0,18	0,2	0,22	0,24	0,26	0,28	0,3
	300	Nm	2	2	2	2	2	2	2	2	2	2	2	2	4	4
		S (m ²)	0,06	0,09	0,12	0,15	0,18	0,21	0,24	0,27	0,3	0,33	0,36	0,39	0,42	0,45
	400	Nm	2	2	2	2	2	2	2	2	2	4	4	4	4	4
		S (m ²)	0,08	0,12	0,16	0,2	0,24	0,28	0,32	0,36	0,4	0,44	0,48	0,52	0,56	0,6
	500	Nm	2	2	2	2	2	2	2	4	4	4	4	4	4	4
		S (m ²)	0,1	0,15	0,2	0,25	0,3	0,35	0,4	0,45	0,5	0,55	0,6	0,65	0,7	0,75
	600	Nm	2	2	2	2	2	4	4	4	4	4	4	4	5	5
		S (m ²)	0,12	0,18	0,24	0,3	0,36	0,42	0,48	0,54	0,6	0,66	0,72	0,78	0,84	0,9
	700	Nm	2	2	2	2	4	4	4	4	4	4	5	5	5	10
		S (m ²)	0,14	0,21	0,28	0,35	0,42	0,49	0,56	0,63	0,7	0,77	0,84	0,91	0,98	1,05
	800	Nm	2	2	2	2	4	4	4	4	4	5	5	10	10	10
		S (m ²)	0,16	0,24	0,32	0,4	0,48	0,56	0,64	0,72	0,8	0,88	0,96	1,04	1,12	1,2
	900	Nm	2	2	2	4	4	4	4	5	5	5	10	10	10	10
		S (m ²)	0,18	0,27	0,36	0,45	0,54	0,63	0,72	0,81	0,9	0,99	1,08	1,17	1,26	1,35
	1000	Nm	2	2	2	4	4	4	4	5	5	10	10	10	10	10
		S (m ²)	0,2	0,3	0,4	0,5	0,6	0,7	0,8	0,9	1	1,1	1,2	1,3	1,4	1,5
	1100	Nm	2	2	4	4	4	4	5	5	10	10	10	10	10	10
		S (m ²)	0,22	0,33	0,44	0,55	0,66	0,77	0,88	0,99	1,1	1,21	1,32	1,43	1,54	1,65
1200	Nm	2	2	4	4	4	5	5	10	10	10	10	10	10	10	
	S (m ²)	0,24	0,36	0,48	0,6	0,72	0,84	0,96	1,08	1,2	1,32	1,44	1,56	1,68	1,8	
1300	Nm	2	2	4	4	4	5	10	10	10	10	10	10	10	10	
	S (m ²)	0,26	0,39	0,52	0,65	0,78	0,91	1,04	1,17	1,3	1,43	1,56	1,69	1,82	1,95	
1400	Nm	2	4	4	4	5	5	10	10	10	10	10	10	10	20	
	S (m ²)	0,28	0,42	0,56	0,7	0,84	0,98	1,12	1,26	1,4	1,54	1,68	1,82	1,96	2,1	
1500	Nm	2	4	4	4	5	10	10	10	10	10	10	10	20	20	
	S (m ²)	0,3	0,45	0,6	0,75	0,9	1,05	1,2	1,35	1,5	1,65	1,8	1,95	2,1	2,25	
1600	Nm	2	4	4	4	5	10	10	10	10	10	10	20	20	20	
	S (m ²)	0,32	0,48	0,64	0,8	0,96	1,12	1,28	1,44	1,6	1,76	1,92	2,08	2,24	2,4	

Note: couple values in the table are intended for a correct movement of the damper.

For dimensions not available in the table, calculate the gross damper surface and refer to values of maximum couple in the list Servomotors.

MAXIMUM COUPLE SERVOMOTOR (Nm)

GROSS DAMPER SURFACE (m²):

			L (mm)													
			200	300	400	500	600	700	800	900	1000	1100	1200	1300	1400	1500
H (mm)	1700	Nm	2	4	4	5	10	10	10	10	10	10	20	20	20	20
		S (m ²)	0,34	0,51	0,68	0,85	1,02	1,19	1,36	1,53	1,7	1,87	2,04	2,21	2,38	2,55
	1800	Nm	2	4	4	5	10	10	10	10	10	10	20	20	20	20
		S (m ²)	0,36	0,54	0,72	0,9	1,08	1,26	1,44	1,62	1,8	1,98	2,16	2,34	2,52	2,7
	1900	Nm	2	4	4	5	10	10	10	10	10	20	20	20	20	20
		S (m ²)	0,38	0,57	0,76	0,95	1,14	1,33	1,52	1,71	1,9	2,09	2,28	2,47	2,66	2,85
	2000	Nm	2	4	4	5	10	10	10	10	10	20	20	20	20	20
		S (m ²)	0,4	0,6	0,8	1	1,2	1,4	1,6	1,8	2	2,2	2,4	2,6	2,8	3
	2100	Nm	4	4	5	10	10	10	10	10	20	20	20	20	20	20
		S (m ²)	0,42	0,63	0,84	1,05	1,26	1,47	1,68	1,89	2,1	2,31	2,52	2,73	2,94	3,15
	2200	Nm	4	4	5	10	10	10	10	10	20	20	20	20	20	20
		S (m ²)	0,44	0,66	0,88	1,1	1,32	1,54	1,76	1,98	2,2	2,42	2,64	2,86	3,08	3,3
	2300	Nm	4	4	5	10	10	10	10	20	20	20	20	20	20	20
		S (m ²)	0,46	0,69	0,92	1,15	1,38	1,61	1,84	2,07	2,3	2,53	2,76	2,99	3,22	3,45
	2400	Nm	4	4	5	10	10	10	10	20	20	20	20	20	20	20
		S (m ²)	0,48	0,72	0,96	1,2	1,44	1,68	1,92	2,16	2,4	2,64	2,88	3,12	3,36	3,6
	2500	Nm	4	4	5	10	10	10	10	20	20	20	20	20	20	20
		S (m ²)	0,5	0,75	1	1,25	1,5	1,75	2	2,25	2,5	2,75	3	3,25	3,5	3,75
	2600	Nm	4	4	10	10	10	10	20	20	20	20	20	20	20	20
		S (m ²)	0,52	0,78	1,04	1,3	1,56	1,82	2,08	2,34	2,6	2,86	3,12	3,38	3,64	3,9
	2700	Nm	4	5	10	10	10	10	20	20	20	20	20	20	20	30
		S (m ²)	0,54	0,81	1,08	1,35	1,62	1,89	2,16	2,43	2,7	2,97	3,24	3,51	3,78	4,05
	2800	Nm	4	5	10	10	10	10	20	20	20	20	20	20	20	30
		S (m ²)	0,56	0,84	1,12	1,4	1,68	1,96	2,24	2,52	2,8	3,08	3,36	3,64	3,92	4,2
	2900	Nm	4	5	10	10	10	20	20	20	20	20	20	20	30	30
		S (m ²)	0,58	0,87	1,16	1,45	1,74	2,03	2,32	2,61	2,9	3,19	3,48	3,77	4,06	4,35
	3000	Nm	4	5	10	10	10	20	20	20	20	20	20	20	30	30
		S (m ²)	0,6	0,9	1,2	1,5	1,8	2,1	2,4	2,7	3	3,3	3,6	3,9	4,2	4,5

Note: couple values in the table are intended for a correct movement of the damper.

For dimensions not available in the table, calculate the gross damper surface and refer to values of maximum couple in the list Servomotors.

MAXIMUM COUPLE SERVOMOTOR (Nm)

GROSS DAMPER SURFACE (m²):

		L (mm)															
		1600	1700	1800	1900	2000	2100	2200	2300	2400	2500	2600	2700	2800	2900	3000	
H (mm)	200	Nm	2	2	2	2	2	4	4	4	4	4	4	4	4	4	
		S (m ²)	0,32	0,34	0,36	0,38	0,4	0,42	0,44	0,46	0,48	0,5	0,52	0,54	0,56	0,58	0,6
	300	Nm	4	4	4	4	4	4	4	4	4	4	4	5	5	5	5
		S (m ²)	0,48	0,51	0,54	0,57	0,6	0,63	0,66	0,69	0,72	0,75	0,78	0,81	0,84	0,87	0,9
	400	Nm	4	4	4	4	4	5	5	5	5	5	10	10	10	10	10
		S (m ²)	0,64	0,68	0,72	0,76	0,8	0,84	0,88	0,92	0,96	1	1,04	1,08	1,12	1,16	1,2
	500	Nm	4	5	5	5	5	10	10	10	10	10	10	10	10	10	10
		S (m ²)	0,8	0,85	0,9	0,95	1	1,05	1,1	1,15	1,2	1,25	1,3	1,35	1,4	1,45	1,5
	600	Nm	5	10	10	10	10	10	10	10	10	10	10	10	10	10	10
		S (m ²)	0,96	1,02	1,08	1,14	1,2	1,26	1,32	1,38	1,44	1,5	1,56	1,62	1,68	1,74	1,8
	700	Nm	10	10	10	10	10	10	10	10	10	10	10	10	10	20	20
		S (m ²)	1,12	1,19	1,26	1,33	1,4	1,47	1,54	1,61	1,68	1,75	1,82	1,89	1,96	2,03	2,1
	800	Nm	10	10	10	10	10	10	10	10	10	10	20	20	20	20	20
		S (m ²)	1,28	1,36	1,44	1,52	1,6	1,68	1,76	1,84	1,92	2	2,08	2,16	2,24	2,32	2,4
	900	Nm	10	10	10	10	10	10	10	20	20	20	20	20	20	20	20
		S (m ²)	1,44	1,53	1,62	1,71	1,8	1,89	1,98	2,07	2,16	2,25	2,34	2,43	2,52	2,61	2,7
	1000	Nm	10	10	10	10	10	20	20	20	20	20	20	20	20	20	20
		S (m ²)	1,6	1,7	1,8	1,9	2	2,1	2,2	2,3	2,4	2,5	2,6	2,7	2,8	2,9	3
	1100	Nm	10	10	10	20	20	20	20	20	20	20	20	20	20	20	20
		S (m ²)	1,76	1,87	1,98	2,09	2,2	2,31	2,42	2,53	2,64	2,75	2,86	2,97	3,08	3,19	3,3
1200	Nm	10	20	20	20	20	20	20	20	20	20	20	20	20	20	20	
	S (m ²)	1,92	2,04	2,16	2,28	2,4	2,52	2,64	2,76	2,88	3	3,12	3,24	3,36	3,48	3,6	
1300	Nm	20	20	20	20	20	20	20	20	20	20	20	20	20	20	20	
	S (m ²)	2,08	2,21	2,34	2,47	2,6	2,73	2,86	2,99	3,12	3,25	3,38	3,51	3,64	3,77	3,9	
1400	Nm	20	20	20	20	20	20	20	20	20	20	20	20	20	30	30	
	S (m ²)	2,24	2,38	2,52	2,66	2,8	2,94	3,08	3,22	3,36	3,5	3,64	3,78	3,92	4,06	4,2	
1500	Nm	20	20	20	20	20	20	20	20	20	20	20	30	30	30	30	
	S (m ²)	2,4	2,55	2,7	2,85	3	3,15	3,3	3,45	3,6	3,75	3,9	4,05	4,2	4,35	4,5	
1600	Nm	20	20	20	20	20	-	-	-	-	-	-	-	-	-	-	
	S (m ²)	2,56	2,72	2,88	3,04	3,2	-	-	-	-	-	-	-	-	-	-	
1700	Nm	20	20	20	20	20	-	-	-	-	-	-	-	-	-	-	
	S (m ²)	2,72	2,89	3,06	3,23	3,4	-	-	-	-	-	-	-	-	-	-	
1800	Nm	20	20	20	20	20	-	-	-	-	-	-	-	-	-	-	
	S (m ²)	2,88	3,06	3,24	3,42	3,6	-	-	-	-	-	-	-	-	-	-	
1900	Nm	20	20	20	20	20	-	-	-	-	-	-	-	-	-	-	
	S (m ²)	3,04	3,23	3,42	3,61	3,8	-	-	-	-	-	-	-	-	-	-	
2000	Nm	20	20	20	20	20	-	-	-	-	-	-	-	-	-	-	
	S (m ²)	3,2	3,4	3,6	3,8	4	-	-	-	-	-	-	-	-	-	-	

Note: couple values in the table are intended for a correct movement of the damper.

For dimensions not available in the table, calculate the gross damper surface and refer to values of maximum couple in the list Servomotors.

TABLE WITH SERVOMOTOR TECHNICAL FEATURES:



		Servomotors without spring-return				
		CM	LM..A	NM..A	SM..A	GM..A
Couple		2 Nm	5 Nm	10 Nm	20 Nm	40 Nm
Universal clamp for pivot dimension (mm):		6-12,7	6-20	8-26	10-20	14-26
For damper until:		0,4 m ²	1 m ²	2 m ²	4 m ²	8 m ²
ON/OFF 3-PUNTI	AC /DC 24 V	CM24-L	LM24A	NM24A	SM24A	GM24A
	AC /DC 24 V with contact auxiliary		LM24A-S	NM24A-S	SM24A-S	
	AC 230 V	CM230-L	LM230A	NM230A	SM230A	GM230A
	AC 230 V with contact auxiliary		LM230A-S	NM230A-S	SM230A-S	
MODULATING Comand 0...10V	AC /DC 24 V	CM24-SR-L	LM24A-SR	NM24A-SR	SM24A-SR	GM24A-SR
	AC /DC 24 V with contact auxiliary					
	AC 230 V		LM230ASR	NM230ASR	SM230ASR	
Mounting bracket *	ETZS1				●	●

		Spring-return servomotors				
		TF	LF	NF	SF	EF
Couple		2,5 Nm	4 Nm	10 Nm	20 Nm	30 Nm
Universal clamp for pivot dimension (mm):		6-12,7	8-16	10-22	10-22	12-26,7
For damper until:		0,5 m ²	0,8 m ²	2 m ²	4 m ²	6 m ²
ON/OFF 3-PUNTI	AC /DC 24 V	TF24	LF24	NF24A	SF24A	EF24A
	AC /DC 24 V with contact auxiliary	TF24-S	LF24-S	NF24A-S2	SF24A-S2	EF24A-S2
	AC 230 V	TF230	LF230	NFA	SFA	EF230A
	AC 230 V with contact auxiliary	TF230-S	LF230-S	NFA-S2	SFA-S2	EF230A-S2
MODULATING Comand 0...10V	AC /DC 24 V	TF24-SR	LF24-SR	NF24A-SR	SF24A-SR	EF24A-SR
	AC /DC 24 V with contact auxiliary			NF24A-SR-S2	SF24A-SR-S2	EF24A-SR-S2
	AC 230 V	TF230-SR				
Mounting bracket *	ETZS2			●	●	●

*bracket to be coupled with standard universal plate, to allow an easy installation of Belimo servomotors as in the table.